

Fieldbus Module FBB-4DI2DO-R.24.AMP

- Connection via BACnet MS/TP
- e.g. for connecting motor-driven fire dampers (monitoring functions for status and running times integrated in the FBB)
- or for general decentralized data points (data collector / remote I/Os)
- Use of pre-assembled connection cables (with AMP connector)
- 4 digital-inputs
- 2 DO, relay outputs, potential-free (I_{max} 16 A)
- Power supply 24 V AC/DC



Technical Data

General Data	Module type	FBB-4DI2DO-R.24.AMP
	Item number	00003218
Electrical Data	Power supply	24 V AC/DC
	Current consumption	depending on data point configuration DC: typ. 56 mA, max. 85 mA AC: typ. 120 mA, max. 160 mA
	Power requirement	depending on data point configuration DC: typ. 1,4 W, max. 2,0 W AC: typ. 2,1 W, max. 3,0 W
Digital Outputs – Relays	Quantity	2 relays, 1 normally open contact (NO), with status LED, local override function
	Potential	potential-free
	max. switching capacity DC1	30 V DC (16 A)
	max. switching capacity DC1	110 V DC (0,3 A)
	max. switching capacity DC1	220 V DC (0,12 A)
	max. switching capacity AC1	4000 VA (16 A / 250 V AC)
	max. switching capacity AC3	500 W / 230 V AC
	max. switching capacity AC15	750 VA / 230 V AC
	Endurance (electrical)	50x10 ³ (at rated load)
max. switching frequency	600 switching cycles per hour at rated load	
Inductive loads	have to be avoided as much as possible or eliminated at the source	
Digital Inputs	Quantity	4 (each with status LED)
	Input voltage	24 V, controlled by potential-free contact via DI and COM
Communication	Protocol / interface	BACnet MS/TP / RS485
	Address setting	via dip switches
	Baud rates	9600, 19200, 38400, 57600, 76800, 115200, 230400 Bd, automatic detection
Safety	Protection class IEC/EN	IP 54 (for .AMP variants)
	Ambient temperature	0 ... 50°C
	Storage temperature	-10 ... 70°C
	Relative humidity	10 ... 90%, not condensing
	Maintenance	maintenance-free
	Weight	approx. 451 g
	Dimensions housing	160x140x81 (WxHxD)
Dimensions including PG-glands	160x172x81 (WxHxD)	

Product features

System description

The **FBB-4DI2DO-R** fieldbus modules provide digital inputs and outputs for decentralized installation in the building. Using the BACnet MS/TP interface, actuators and messages can be interconnected.

In addition to just controlling the outputs and reading the inputs using bus commands, the **FBB modules** also provide the option of configuring certain functions, such as status and runtime monitoring of motorized fire dampers. If this function is deactivated, the devices are operated as simple data collectors or remote I/Os.

The outputs can be overridden manually using a push-button:

Action	Status/Change	Meaning
	Original state	FD automatic mode
Button pressed 1st time	→	FD manually OPENED
Button pressed 2nd time	→	FD manually CLOSED
Button pressed 3rd time	→	



Feedback whether the digital outputs are manually overridden is given via LEDs in the module and via BACnet status; resetting the outputs to automatic mode is also possible via BACnet command.

Installation

The **FBB modules** are mounted decentrally in the immediate vicinity of sensors and actuators, e.g. directly next to motorized fire dampers, or in the case of heating circuits directly near the ventilation unit or in rooms with individual room control.

Connections

All terminals can be operated without tools (push-in technology and operating lever).
Wire cross sections:
up to 4 mm² (single-wire and fine-stranded conductors)
up to 2,5 mm² (fine-stranded conductors with wire end ferrules)
Connection of the FD actuator and limit switches via pluggable connections using pre-assembled connection cables (AMP connector)

Status LEDs, meaning

Bus	Green, steady light Orange, flashing Red, flashing	Module ready for operation Communication active Faulty or invalid telegram received
Digital outputs	LED off LED Green, steady light LED Orange, steady light LED Green, flashing LED Orange, flashing LED Red, steady light LED Red, flashing	DO AUTO, status 'inactive' ('close'), <i>Priority Array empty</i> DO AUTO, status 'active' ('=open') DO AUTO, status 'inactive' ('=close') DO overridden, status 'active' ('=open') DO overridden, status 'inactive' ('=close') Error message from fire damper Fire damper triggered
Digital inputs	LED Orange, ON	DI, logical state 'active'

BACnet MS/TP, general notes

Addressing	DIP switch, 8-pole 	Addresses 0 ... 254 When setting an address from 0 to 127, the device behaves as a master. If an address in the range from 128 to 254 is set, the device will behave as a slave.
Termination	DIP switch, 4-pole	Dips 1+2 should be set to the ON position on the last device of the bus segment to terminate the bus.
Recommended cable types	up to 100m: more than 100m:	LiYCY 2x2x0,5mm ² , shielded Resistance < 4,0Ω / 100m Capacitance < 13.0nF / 100m CYPiMF 2x2x0,5mm ² , shielded Resistance < 4,0Ω / 100m Capacitance < 6.0nF / 100m

Electrical connection diagram

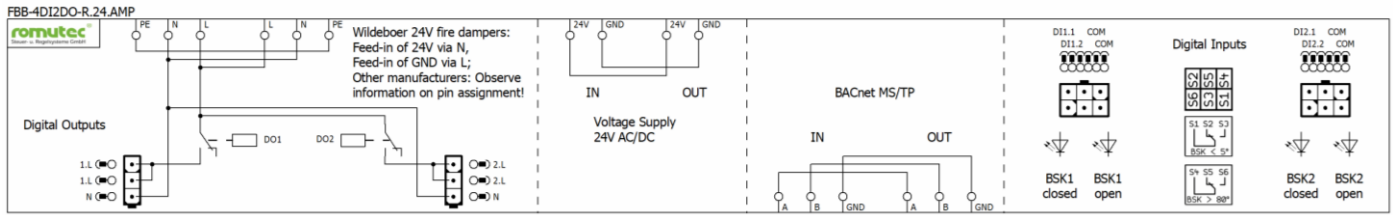

Connection example

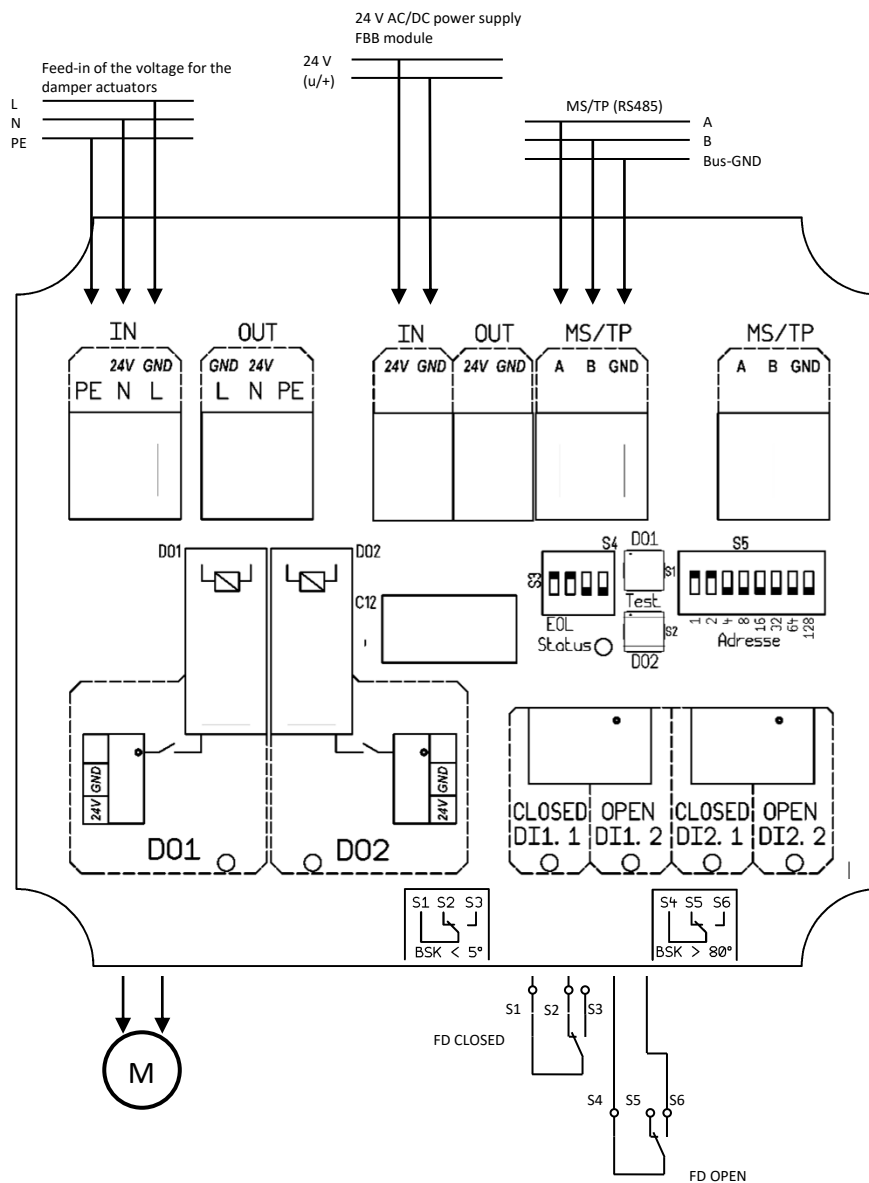

Notes:

DO1 = 1L, DO2 = 2L: The output voltage for 1L and 2L must be applied to terminal L. If 24 V damper actuators are used, this voltage must be fed into L (24 V) and N (0 V) accordingly.

For **Wildeboer** 24V dampers, the 24V supply is via N, and the GND supply is via L. For fire dampers from other manufacturers, please refer to their connector specifications.

Safety instructions



- The **FBB module** should not be installed in the immediate vicinity of frequency converters. Frequency converters must be wired with all protective measures so that the required regulations and guidelines are complied with (e.g. mains filter, etc.).
- The supply voltage must be as described in the documentation.
- The connection terminals located inside the device should only be wired by authorised, trained specialist personnel.
- Do not carry out wiring on live parts. There is a danger of electric shock, as some terminals may carry 230 V. Generally, avoid connecting and loosening plug connections when the system is live.
- All legal and official regulations must be adhered to.
- Make sure that no objects such as screws or other fixing materials get into the device.
- This device is designed for use in stationary heating, ventilation and air conditioning systems and may not be used outside the specified scope of application.
- Avoid installing in locations with extreme and rapid temperature fluctuations. Please note that outdoor usage is only possible if no water, snow, ice, sunlight and aggressive gases affect the device. The ambient conditions for storage and operation given in the data sheet must be complied with in order to ensure fault-free operation.

Further documentation

Web: <http://www.romutec.de>

Additional notes

Copyright

Copyright © 2025 **romutec**[®] Steuer- u. Regelsysteme GmbH. All rights reserved. Without the express written permission, this manual may not be reproduced, transmitted, transcribed, stored in a data recording system, or translated into any language or computer language, neither in whole or in part. This applies to any form and any means, whether electronic, mechanical, magnetic, optical, manual, or any other way.

Support: info@romutec.de

romutec[®]
Steuer- u. Regelsysteme GmbH
Jochsberger Straße 39
91592 Buch am Wald
Tel +49 (0)9867 9790-0
E-Mail: info@romutec.de
<http://www.romutec.de>

romutec[®]
Steuer- u. Regelsysteme GmbH

Return of old devices



Electrical devices of the romutec brand fall within the scope of the ElektroG (Electrical and Electronic Equipment Act) and must not be disposed of in household waste or similar. The return of romutec brand old devices is handled through our return service, which we have set up for our B2B customers. You can request a return via altgeraete@romutec.de or by phone at +49-9867-97900. This ensures that the devices are properly recycled and disposed of in accordance with legal requirements.
WEEE-Reg.-No. DE 65277688